

# PC/104 Connector

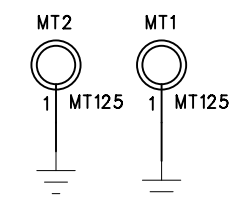

Technologic Systems	Date Nov. 15, 2007
Title: TS-Relay8	
Rev: 1.0	Designer RLM
Sheet 1 of 2	

# Relays

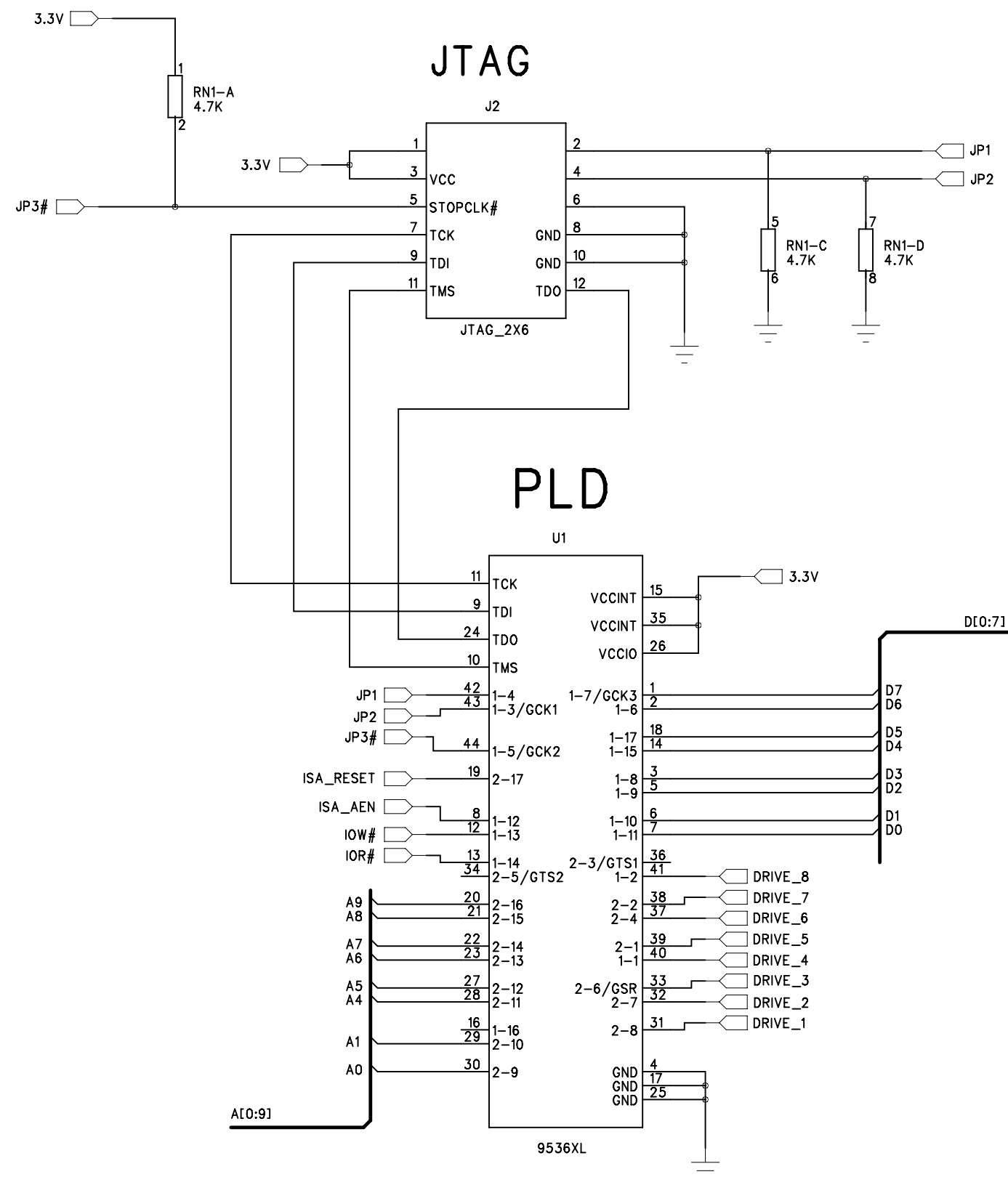
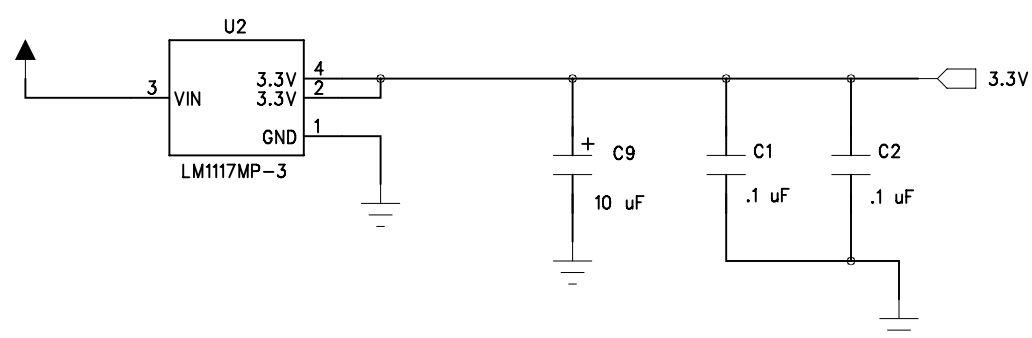
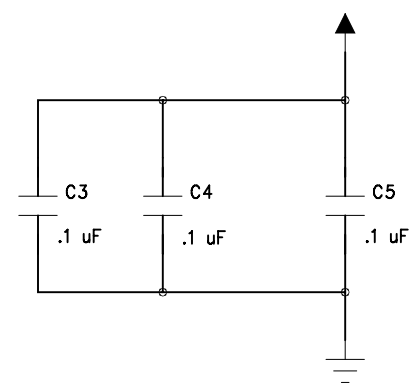
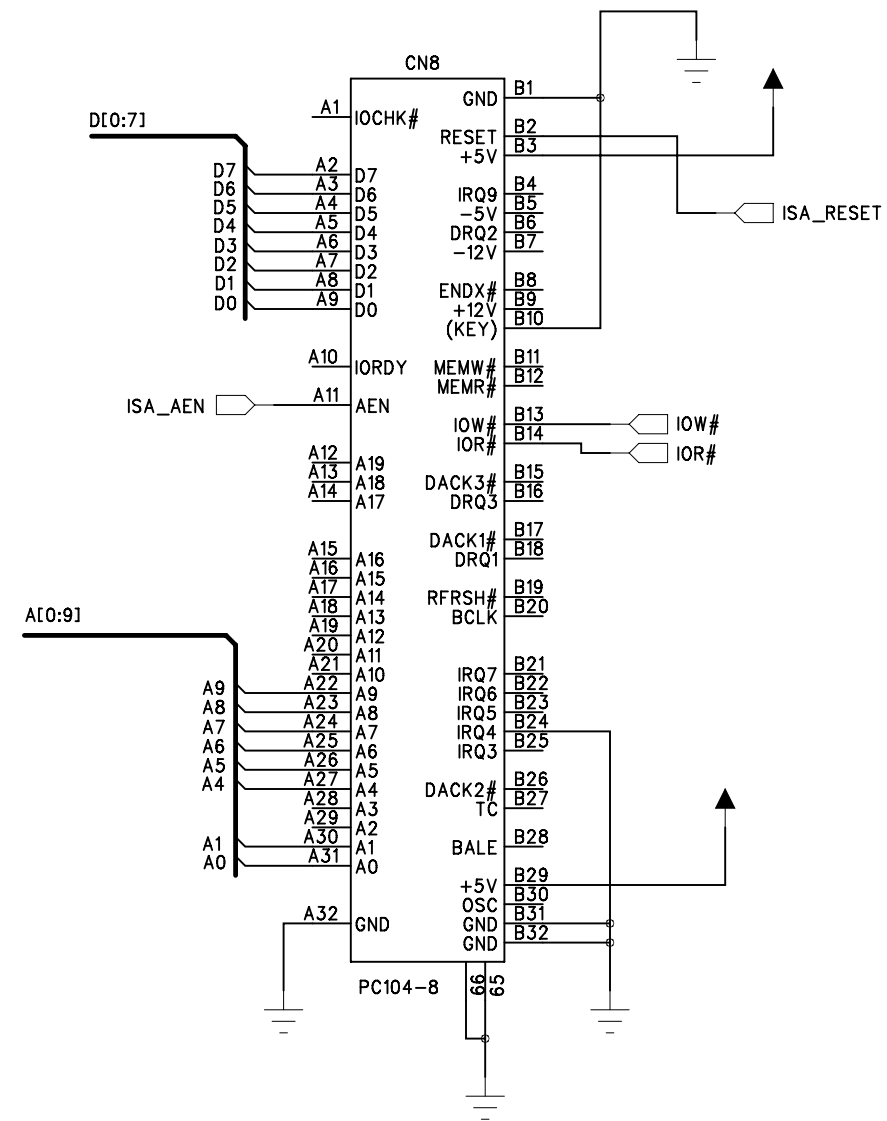
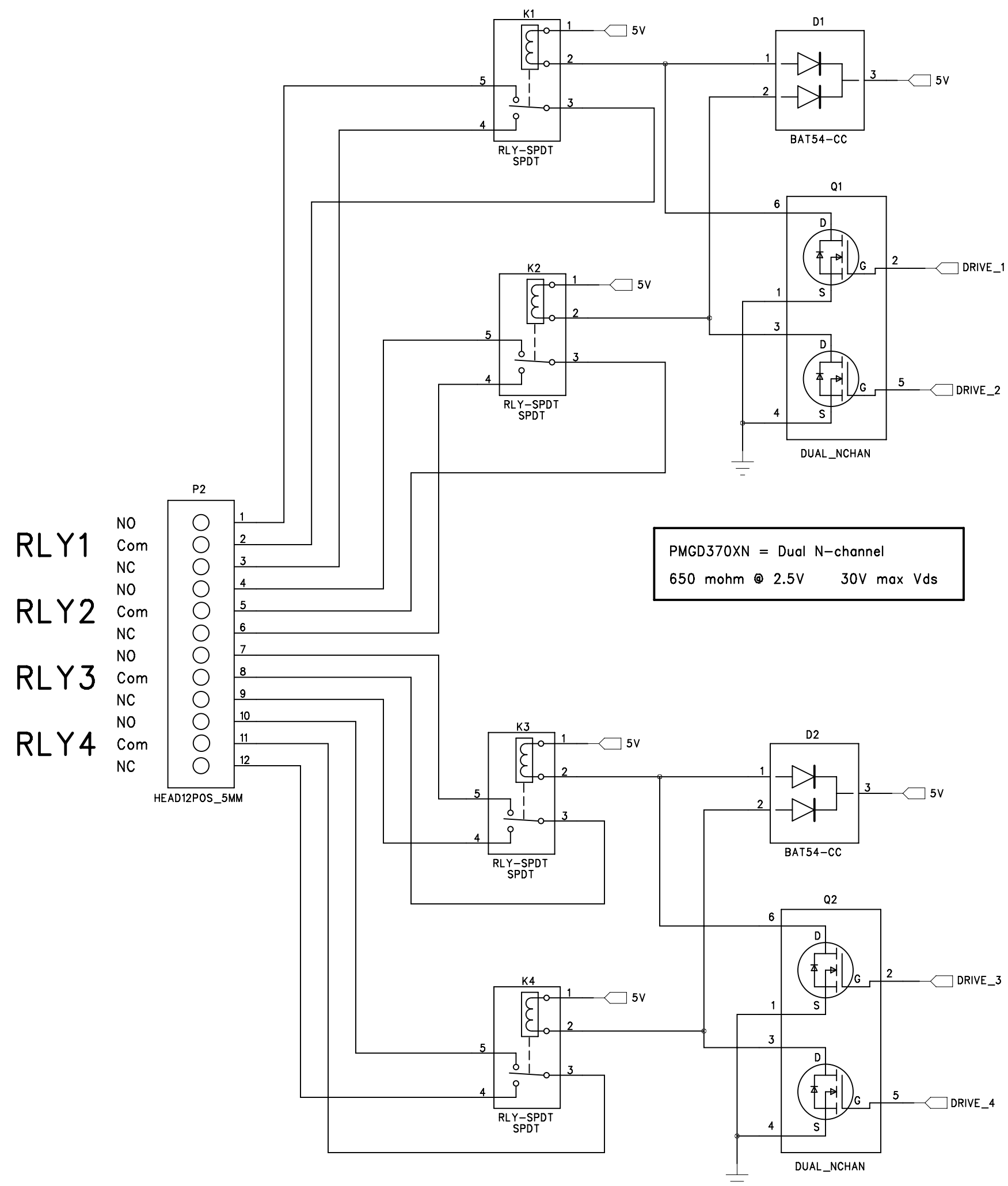

PMGD370XN = Dual N-channel  
650 mohm @ 2.5V 30V max Vds

PB890 = SPDT 5V Relay  
10A @ 125 VAC resistive  
5A @ 277VAC or 30VDC resistive

PB353-ND is shorter (0.4 inches)  
and has only 40 mA coil  
but it is \$2.60 @ 100

Omron Z1640-ND is also second source  
but is 0.62 inches tall

# Relays

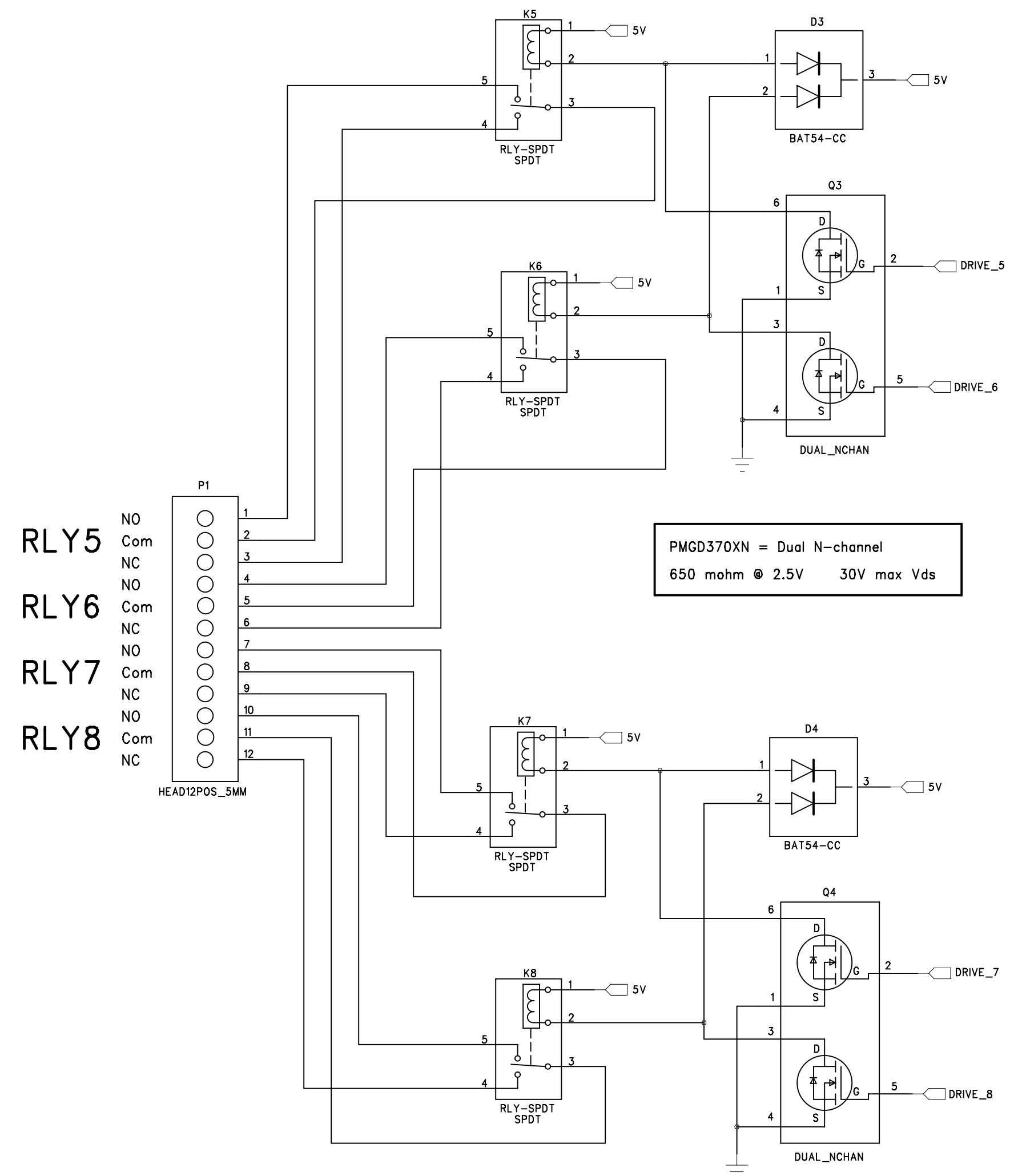

PMGD370XN = Dual N-channel  
650 mohm @ 2.5V 30V max Vds